

1200HTHxxxCV 1200W AC/DC CC/CV LED Driver

Features

- Dimming port programming without driver power on
- 187-528VAC wide range high line input
- CC/CV hybrid output
- High efficiency (typical 96%), active power factor correction
- Ultra low THD at light load
- Isolated 0~10V/ PWM/Rset dimming, Dim to off option
- 12V/200mA AUX Output

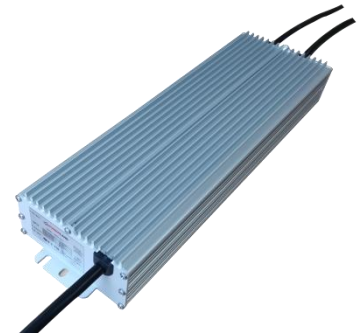

Description

1200W LED Drivers offers digital programmable drivers with wide-range adjustable output current, together with 12V/200mA auxiliary output for smart lighting.

The output current of this series are programmable, and designed for 0-10V/PWM/Rset dimming applications.

Model Name Definition

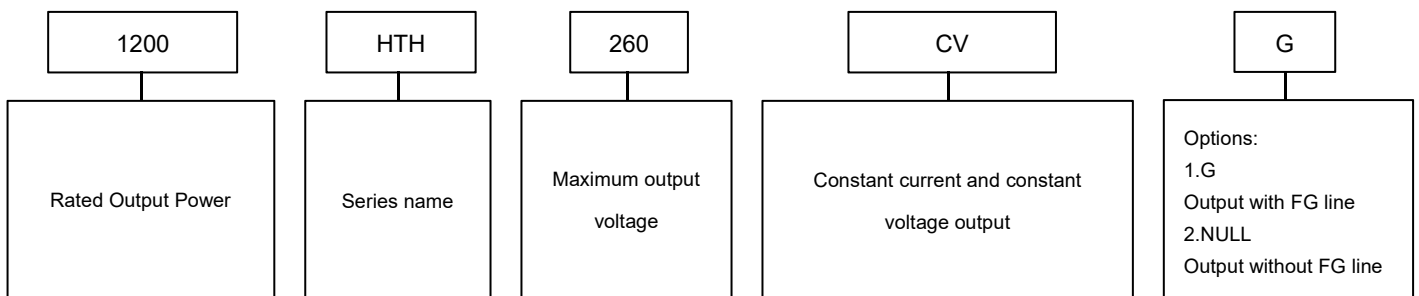

Specifications

Part Number	PO_MAX (W)	IO_RANGE @ CC (A)	VO_RANGE (V)	VO_RANGE @CV (V)	Typical η (%) @ 400 VAC
1200HTH56CV	1200	10.00-25.00	28-56	48-56	96
1200HTH180CV	1200	3.33-8.33	86-180	144-180	95
1200HTH260CV	1200	2.31-5.77	124-260	208-260	96

Table of Contents

1. Input Specifications	2
2. Output Specifications	2
3. General Specifications	3
4. Dimming Specifications	3
5. Isolation	4
6. Safety & EMC Compliance	4
7. Performance Curve	5
7.1. Inrush Current Curve	5
Figure 1. Inrush Current @ full load and cold start	5
7.2. Derating Curve	5
Figure 2. Input Voltage Derating Curve	5
7.3. Lifetime Curve	6
Figure 3. Life vs Case Temperature	6
7.4. Operation Range Curve	6
Figure 4. I/V Operating Area (1200HTH56CV)	6
Figure 5. I/V Operating Area (1200HTH180CV)	6
Figure 6. I/V Operating Area (1200HTH260CV)	6
7.5. General Performance Curve	7
Figure 7. Total Harmonics vs Different Loads	7
Figure 8. Efficiency vs Different Loads	7
Figure 9. Power Factor vs Different Loads	7
7.6. 0-10V Analog Dimming & PWM Dimming	7
Figure 10. The Block Diagram of 0-10V Analog Dimming	7
Figure 11. Io/Io _{set} vs Dimming Voltage	7
Figure 12. The Block Diagram of PWM Dimming	8
Figure 13. Io/Io _{set} vs PWM Duty Cycle	8
Figure 14. The Block Diagram of Resistor Dimming	8
Figure 15. Io/Io _{set} vs Rx	8
8. Programming wiring diagram	9
Figure 16. Programming Wiring	9
9. Mechanical Specification	10
Figure 17. Mechanical Drawing	10
10. Ordering information	10
11. Revision History	11

1. Input Specifications

	Parameter	Min.	Typ.	Max.	Unit	Notes
V_{IN_AC}	Rated Input AC Voltage	208	-	480	VAC	The upper limit voltage of CE certification:400 VAC
V_{IN_RANGE}	Input AC Voltage Range	187	-	528	VAC	
F_{LINE}	Input Frequency	47	-	63	Hz	
I_{LKG}	Leakage Current	-	-	0.75	mA	At 480 VAC/ 60 Hz input , grounding effectively
I_{IN_AC}	Input AC Current	-	-	6.6	A	Measured at 25°C, full load and 208 VAC input.
I_{PK_INRUSH}	Inrush Peak Current	-	-	35	A	At 480 VAC input, 25°C cold start. See Inrush Current Waveform for the details.
PF	Power Factor	0.9	-	-		At 208-480, full load, 25°C and 50 Hz
THD	Total Harmonic	-	-	20	%	
η	Efficiency	95	96	-	%	Measured at 400 VAC input, 100% load and steady-state temperature in 25°C ambient (1200HTH56CV & 1200HTH260CV)

2. Output Specifications

	Parameter	Min.	Typ.	Max.	Unit	Notes
I_{O_ACCU}	Output Current Accuracy relative to I_o set	-5	-	5	%	At 25°C and full load condition. Can contact sales ask for better current tolerance.
I_{O_RIPPLE}	Total Output Current Ripple (pk-pk) relative to I_o max	-	-	10	%	At 25°C and full load condition, 8 kHz BW
$I_{O_OVERSHOOT}$	Startup Overshoot Current relative to I_o max	-	-	20	%	At 25°C and full load condition, 8 kHz BW
V_{O_OCV}	No Load Output Voltage	-	58	59	V	1200HTH56CV
		-	190	-	V	1200HTH180CV
		-	275	290	V	1200HTH260CV
V_{O_LINE}	Line Regulation	-	-	±1	%	Measured at 25°C and full load
V_{O_LOAD}	Load Regulation	-	-	±2	%	At 25°C condition
T_{ON_DELAY}	Turn-on Delay Time	-	0.8	1.5	s	Measured at 277 VAC input.
I_{O_TC}	Temperature Coefficient of I_o set	-0.05	-	0.05	%/°C	Case temperature = 0°C ~Tc max
V_{O_AUX}	12V Auxiliary Output Voltage	11	12	15	V	
I_{O_AUX}	12V Auxiliary Output Current	0	-	200	mA	Return terminal is “Dim-“
T_{OTP}	Over Temperature Protection Threshold	90	-	100	°C	Output current will drop to 50% lowest, or shut down.

SCP	Short Circuit Protection Threshold					Auxiliary source: Hiccup mode, Auto recover Main output: Locked or auto recover
OCP	Over Current Protection Threshold					Locked or auto recover

3.General Specifications

	Parameter	Min.	Typ.	Max.	Unit	Notes
P _{STANDBY}	Standby power	-	-	1	W	Measured at 277 VAC/60 Hz ; Dimming off
T _{MTBF}	Mean Time Between Failure	234,000	-	-	Hours	Measured at 277 VAC input, 80% load and 25°C ambient temperature (MIL-HDBK-217F)
T _{LIFETIME}	Lifetime	50,000	-	-	Hours	Measured at 400 VAC input, 100% load and 75°C case temperature; See lifetime vs. Tc curve for the details
T _C	Operating Case Temperature	-40	-	90	°C	Under harsh conditions, when tc>80°C or ta>45°C, it may trigger automatic derating to around 85%.
T _A	Operating Ambient Temperature	-40	-	50	°C	
T _{STG}	Storage Temperature	-40	-	85	°C	Humidity: 5%RH to 100%RH
	IP Grade	IP65				
	Dimensions	16.93 × 3.89 × 1.81			inch	
	L × W × H	430 × 98.8 × 46.1			mm	
	Net Weight	-	4.4	-	kg	

4.Dimming Specifications

Parameter	Min.	Typ.	Max.	Unit	Notes
Absolute Maximum Voltage on the Vdim (+) Pin	-1	-	12	V	
Source Current on Vdim (+)Pin	90	100	110	uA	
Dimming Output Range	-	10 I _{o set}	I _{o set}	%	80%I _{o max} ≤ I _{o set} ≤ 100%I _{o max}
	-	8 I _{o max}	I _{o set}	%	I _{o set} < 80%I _{o max}
Recommended Dimming Input Range	0	-	10	V	Default 0-10V dimming mode.
Dim off Voltage	0.6	0.8	1.0	V	
Dim on Voltage	0.8	1.0	1.2	V	
Dim off Resistance	5	8	10	kΩ	
Dim on Resistance	7	10	12	kΩ	
Hysteresis	-	0.2	-	V	
PWM_in High Level	9.8	10	10.2	V	

PWM_in Low Level	-0.3	-	0.6	V
PWM_in Frequency Range	0.5	-	3	KHz
PWM_in Duty Cycle	1	-	100	%
PWM Dimming off	4	7	10	%
PWM Dimming on	6	9	12	%

5. Isolation

Isolation	AC Input	DC Output	Dimming (SELV)	Housing
AC Input	/	Double isolation	Double isolation	Basic
DC Output	Double isolation	/	Basic	Basic
Dimming	Double isolation	Basic	/	Basic
Housing	Basic	Basic	Basic	/

6. Safety & EMC Compliance

Safety Category	Standard
UL/CUL	UL8750,CAN/CSA-C22.2 No. 250.13-12
CE	EN61347-1
Dielectric Strength(Hi-pot)	Primary to Secondary: 3600 VAC 10mA max.
	Primary to Earth: 1960 VAC 10mA max.
	Secondary to Earth: 500 VAC 10mA max.(1200HTH56CV) 1380 VAC 10mA max.(1200HTH180CV) 1560 VAC 10mA max.(1200HTH260CV)
	Dimming to Secondary: 500 VAC 10mA max.(1200HTH56CV) 1380 VAC 10mA max.(1200HTH180CV) 1560 VAC 10mA max.(1200HTH260CV)
Insulation Resistance	50Mohm min.@ primary to secondary add 500Vdc test voltage
Grounded Resistance	0.1Ω max. @ 25A, 1 minute
EMI Standards	Notes
EN55015	ANSI C63.4:2009 Class B
	This device complies with Part 15 of the FCC Rules. Operation is subject to the following two conditions: (1) this device may not cause harmful interference, and (2) this device must accept any interference received, including interference that may cause undesired Operation.
EMS Standards	Notes
EN 61000-4-2	Electrostatic Discharge (ESD): 8 kV air discharge, 4 kV contact discharge, criteria A
EN 61000-4-3	Radio-Frequency Electromagnetic Field Susceptibility Test-RS, criteria A
EN 61000-4-4	Electrical Fast Transient / Burst-EFT: level 3, criteria B
EN 61000-4-5	Surge Immunity Test: AC Power Line: line to line 4 kV, line to earth 6 kV, criteria B
EN 61000-4-6	Conducted Radio Frequency Disturbances Test-CS, criteria A
EN 61000-4-8	Power Frequency Magnetic Field Test, criteria A
EN 61000-4-11	Voltage Dips, criteria B
EN IEC 61547	Electromagnetic Immunity Requirements Applies To Lighting Equipment

Note: This LED driver meets the EMI specifications above, but EMI performance of a luminaire that contains it depends also on the other devices connected to the driver and on the fixture itself.

7. Performance Curve

7.1. Inrush Current Curve

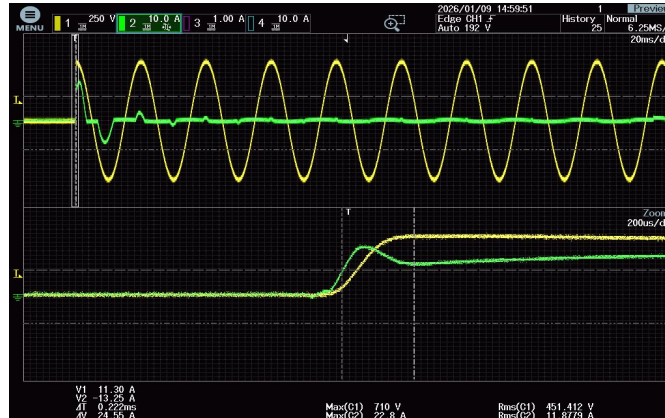

Figure 1. Inrush Current @ full load and cold start

Vin(VAC)	F _{LINE} (Hz)	I _{PK_INRUSH} (A)	T _{DURATION} (ms)
208	60	10.8	0.181
277	60	13.4	0.202
480	60	22.8	0.222

7.2. Derating Curve

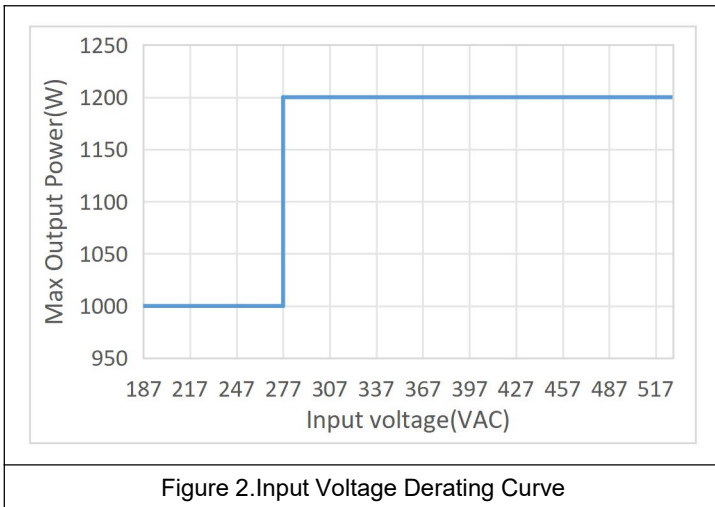

Figure 2. Input Voltage Derating Curve

7.3.Lifetime Curve

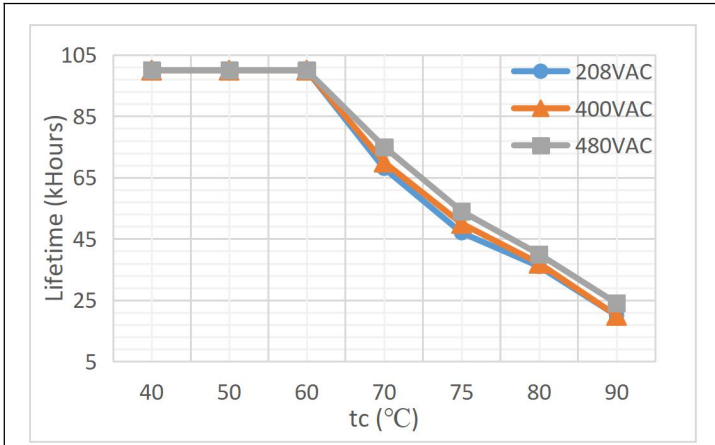

Figure 3.Life vs Case Temperature

7.4.Operation Range Curve

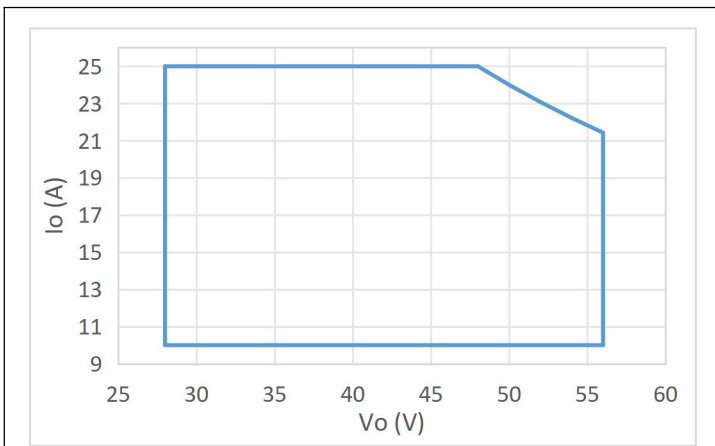

Figure 4.I/V Operating Area (1200HTH56CV)

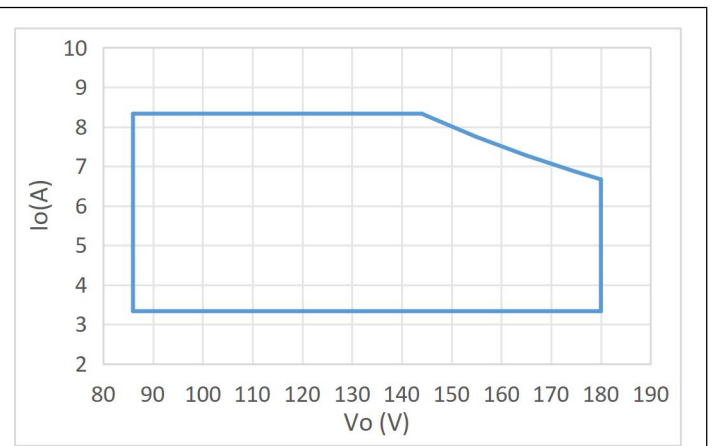

Figure 5.I/V Operating Area (1200HTH180CV)

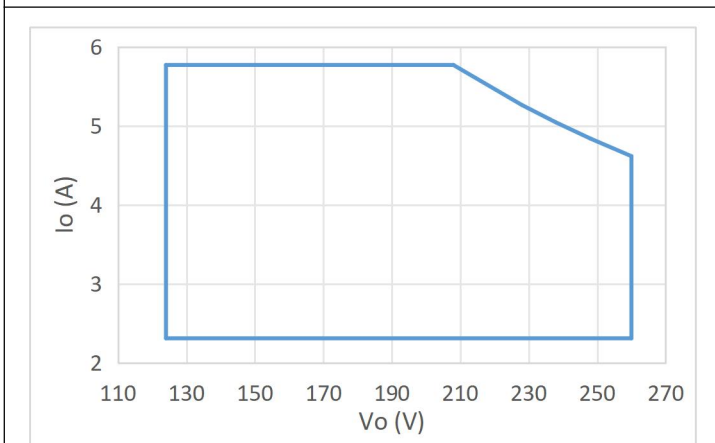

Figure 6.I/V Operating Area (1200HTH260CV)

7.5.General Performance Curve

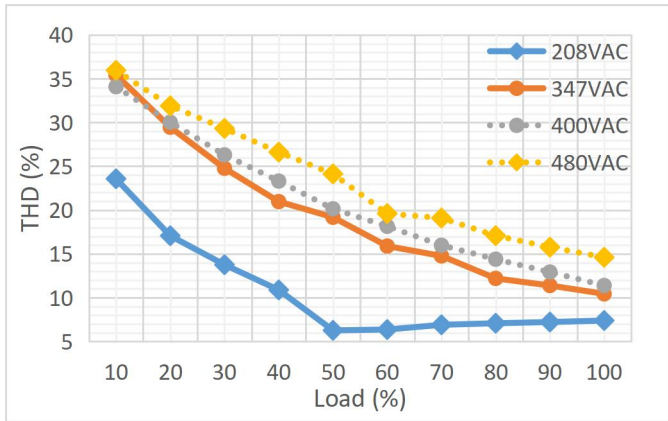

Figure 7.Total Harmonics vs Different Loads

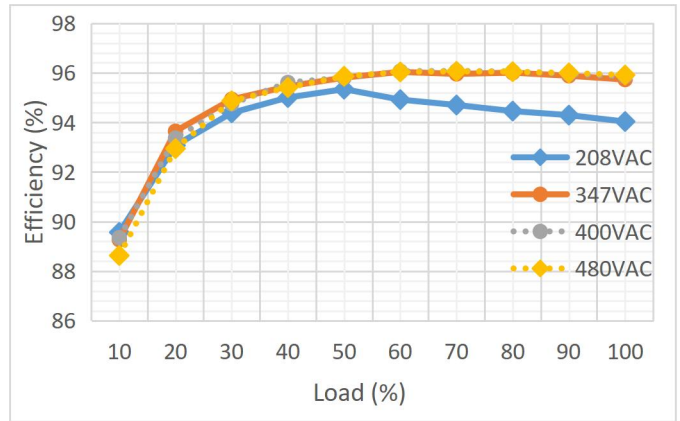

Figure 8.Efficiency vs Different Loads

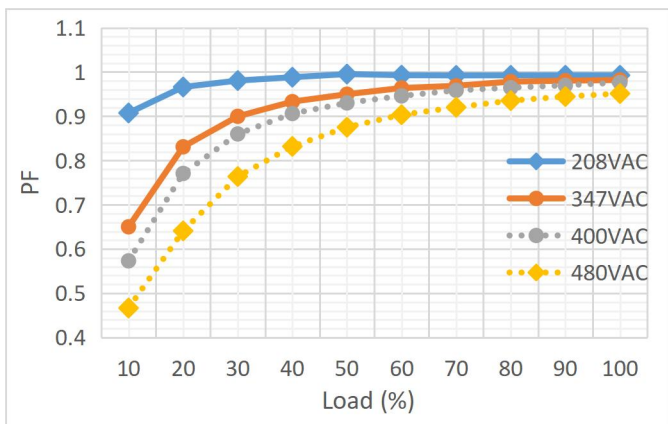

Figure 9.Power Factor vs Different Loads

7.6.0-10V Analog Dimming &PWM Dimming

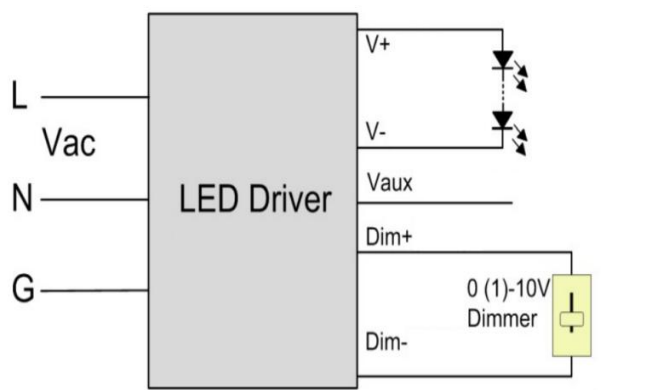

Figure 10.The Block Diagram of 0-10V Analog Dimming

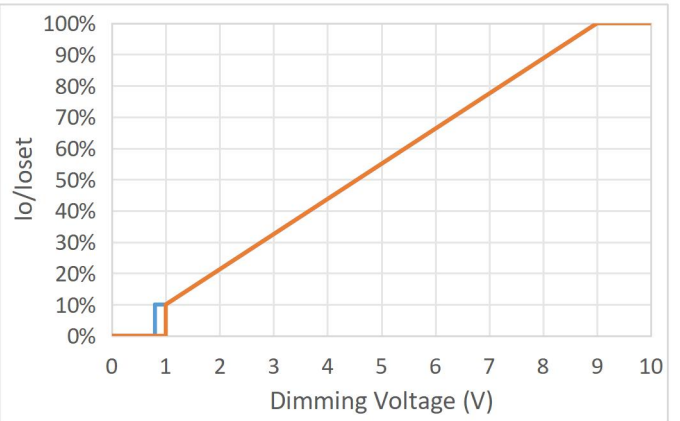

Figure 11.Io/Ioset vs Dimming Voltage

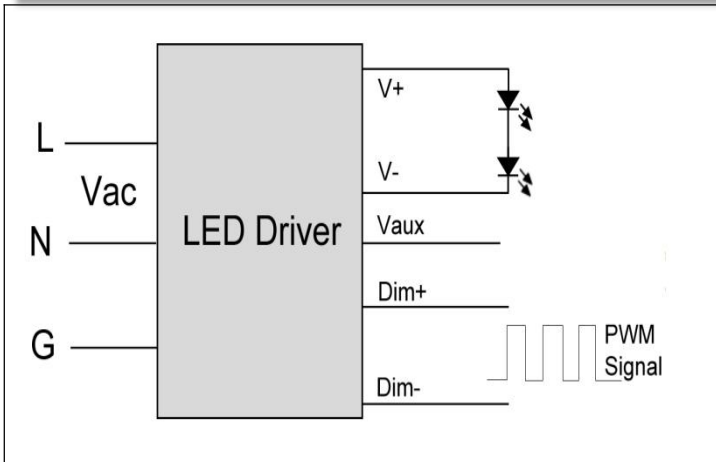

Figure 12. The Block Diagram of PWM Dimming

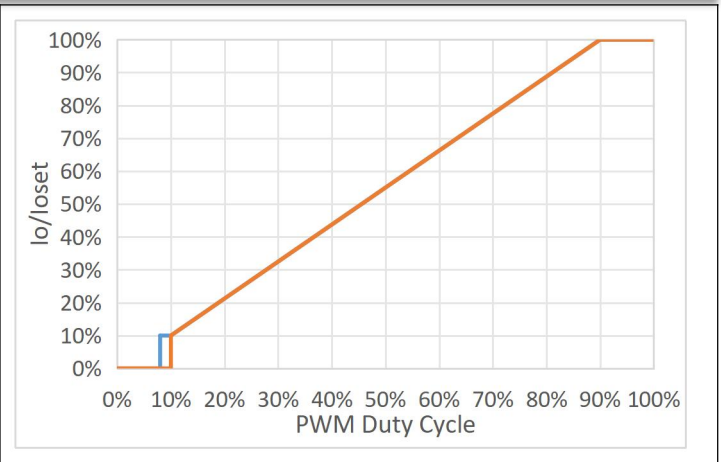

Figure 13. I_o/I_{oSet} vs PWM Duty Cycle

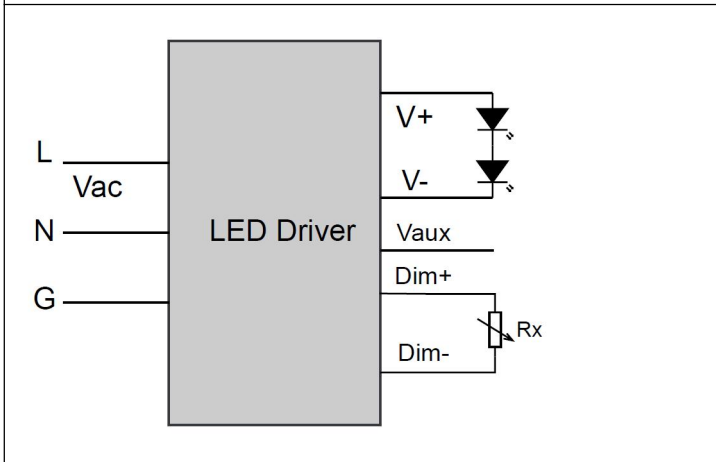

Figure 14. The Block Diagram of Resistor Dimming

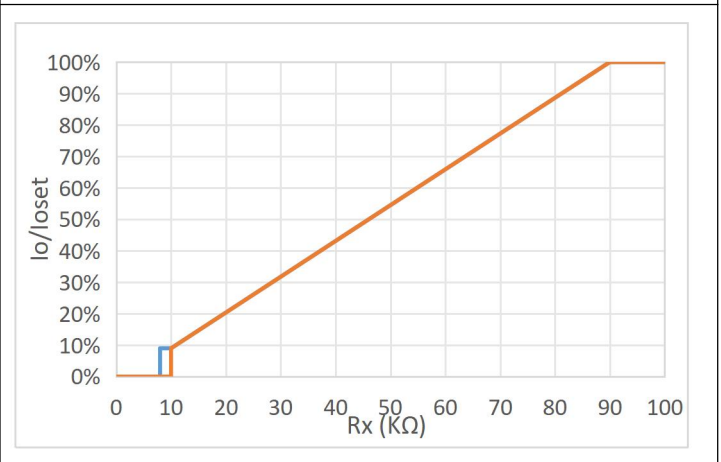

Figure 15. I_o/I_{oSet} vs R_x

8.Programming wiring diagram

- Programmer:Supro1.0
- Software:Supro1.0

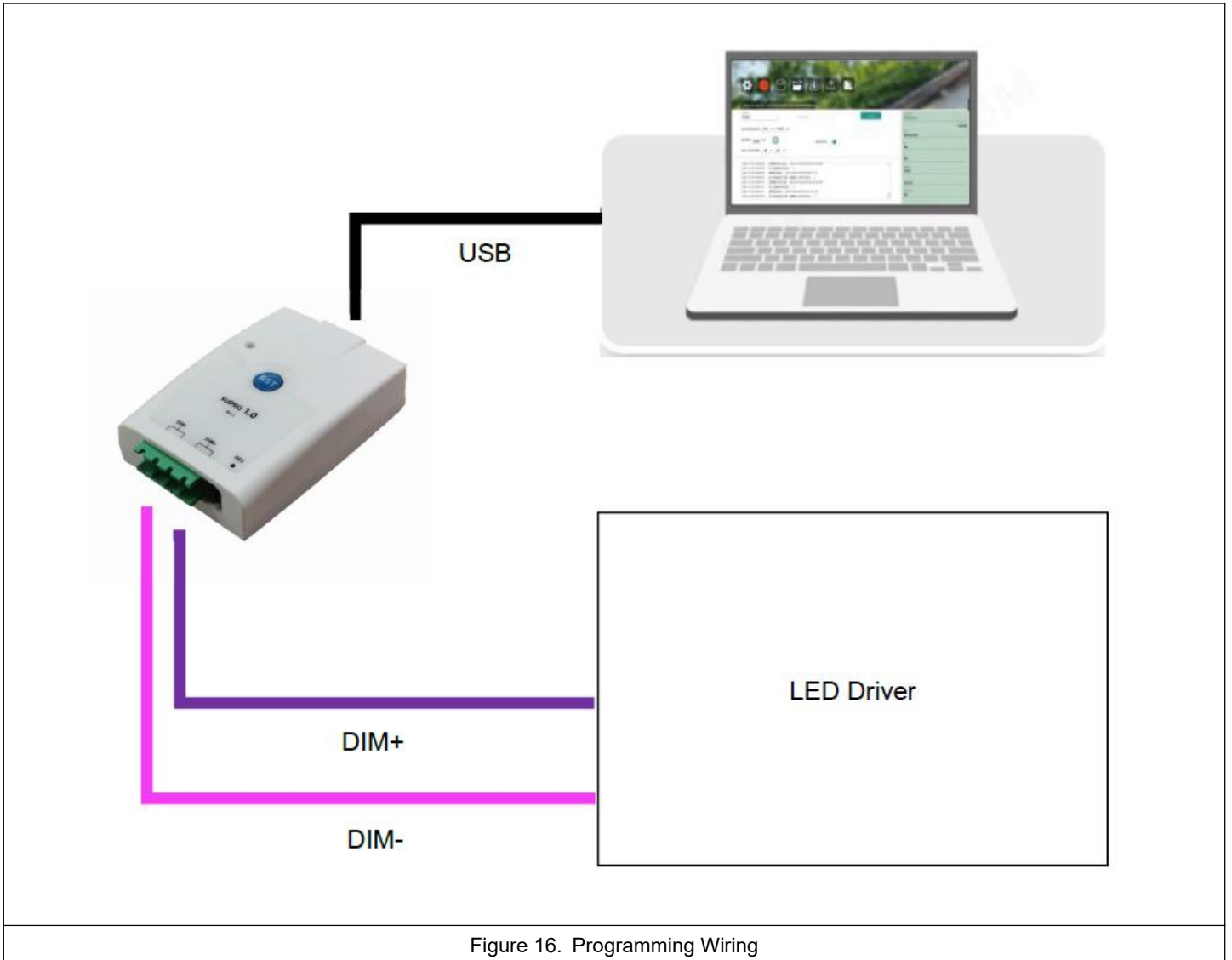

Figure 16. Programming Wiring

Note1:Please download related documents on the website or ask sales for help.

Website like:https://led.powerlandtech.com/product_new/Other.

9.Mechanical Specification

Take 1200HTH260CVG&1200HTH180CVG as a example:

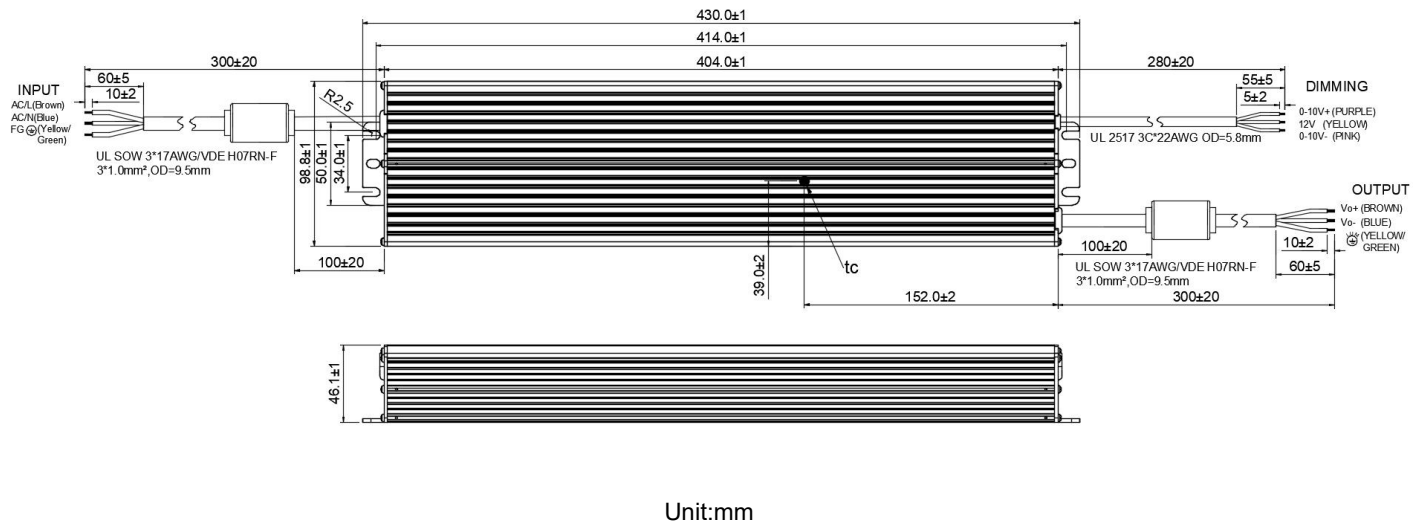

Take 1200HTH56CV as a example:

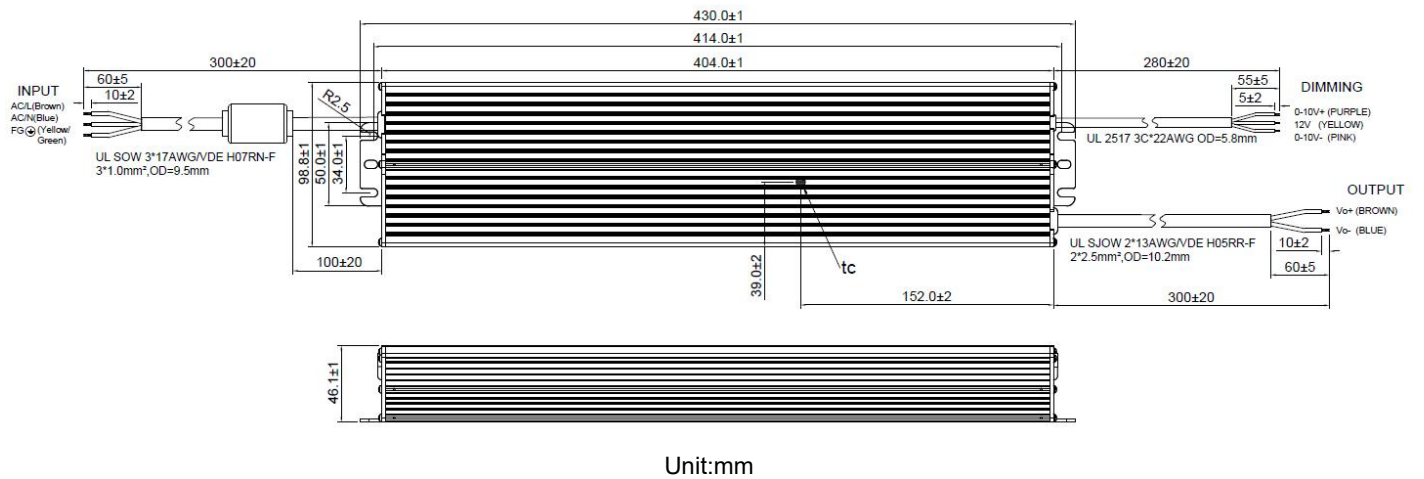

Figure 17. Mechanical Drawing

10.Ordering information

Part Number	Rated Input AC Voltage (VAC)	Channels output	Output whether with FG line	Dimming
1200HTH56CVG	208-480	1	With	0-10V
1200HTH180CVG	208-480	1	With	0-10V
1200HTH260CVG	208-480	1	With	0-10V
1200HTH56CV	208-480	1	Without	0-10V
1200HTH180CV	208-480	1	Without	0-10V
1200HTH260CV	208-480	1	Without	0-10V

11.Revision History

Change Date	Rev.	Description of Change		
		Item	From	To
2025/3/19	V1.0			